

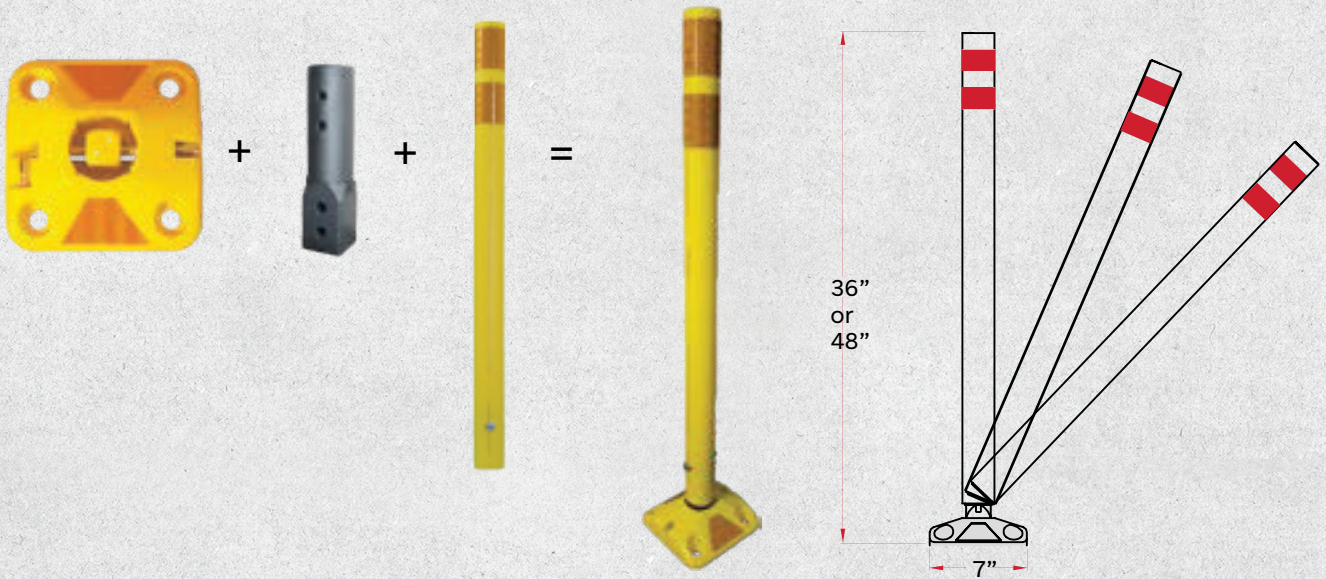

# SHUR-FLEX® SURFACE MOUNT



## FEATURES

- Utilizes the patented Shur-Flex system
- Non-mechanical flexible design is self-righting upon impact
- Multiple reflectivity options
- Multiple base options
- Premium UV added for long lasting color
- Base can be bolted or epoxied
- NTPEP tested, MUTCD compliant

## SPECIFICATIONS

### Shur-Flex® System - 3 Component Design

- The flexible square to round joint is a simple one piece, non-metallic molded design that withstands multiple impacts assuring long-life in corrosive environments.
- Posts are manufactured with greater wall thickness to provide structural integrity.
- Standard posts are round top providing 360 degrees of reflectivity but can be permanently sealed and partially flattened to accommodate up to a 3" x 12" piece of reflective sheeting.
- All post colors or styles are interchangeable with any product utilizing the Shur-Flex® system. Making the Shur-Flex® system the most versatile on the market today.
- Multiple base options. 7"x 7", 7"x 10", and slope base.

### Measurements and Specs

Post Diameter: 2.25" OD  
Post Heights: 18" up to 48"  
Materials: High Density Thermoplastic

### Available Post Colors

- White
- Yellow
- Black
- Orange

### Available Base Colors

- White
- Yellow
- Black
- Orange